



ULTRACRAFT A2D

User Friendly
Digital Transformation
3D Printer for Smart Manufacturing



HeyGears was founded in 2015 as an innovation-driven company, devoted to providing digital manufacturing solutions in various industries. The company bases its core competencies in 3D printing, software development, materials, and big-data handling. We have a global presence with teams across North America, Latin America, Europe, Middle East, and Asia Pacific.

HeyGears believes in a product development process rooted deeply into vertical applications, and our vision goes beyond just 3D printing technology. We strive to create vertically integrated solutions through the solid establishment of hardware, software, material, and service platforms, delivering our goal to bring advanced technology into daily life.

HEYGEARS

www.heygears.com

sales@heygears.com

+1 (318) 353-4295 (Global) / +1 (949) 418-9418 (USA) / +44 148-396-8549 (Europe)

USA: 17931 Sky Park Circle, Suite E, Irvine, CA, 92614

CHN: Block B2, 501, 601, Enterprise Accelerator, Kaifa District, Guangzhou, Guangdong, China



Follow us @HeyGears

ULTRACRAFT A2D

UltraCraft A2D is an entry-level smart manufacturing 3D printer designed for dental applications, which integrates HeyGears's capabilities in DLP 3D printing, production processes, and operational system optimization. Based on HeyGears' closed-loop chain, it can provide the most practical and agile solutions, helping dental labs quickly establish their digital capabilities for better product quality and faster production speed.

01 Outstanding Precision
Multi-application Printing

03 Lightweight and Compact
Easy to Get Started

02 Convenient Printing
Adapting to Various Environments

04 Over-the-air Updates
Up-to-date Performance

05 Integrated Connection
One-stop Complete Production

07 Support for Digitalization

06 Complete Dental Production
Covering a Variety of Applications

08 Specifications

C O N T E N T S

01 Outstanding Precision Multi-application Printing

A2D is designed based on the needs of dental labs, capable of producing fine print results and supporting common applications.



±37.5 µm Build Precision

Excellent 3D printing capabilities of DLP allow for accurate results.



385 nm UV Light Source

Wider application use compared to 415 nm wavelength.

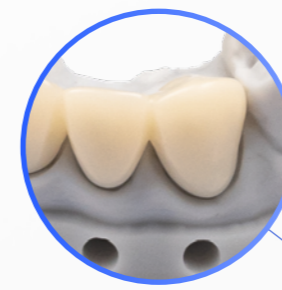

Sectioned Model



Implant Model



Unsectioned Model



Removable Restoration Model

Large Surface Exposure Printing Technology
High-speed Build

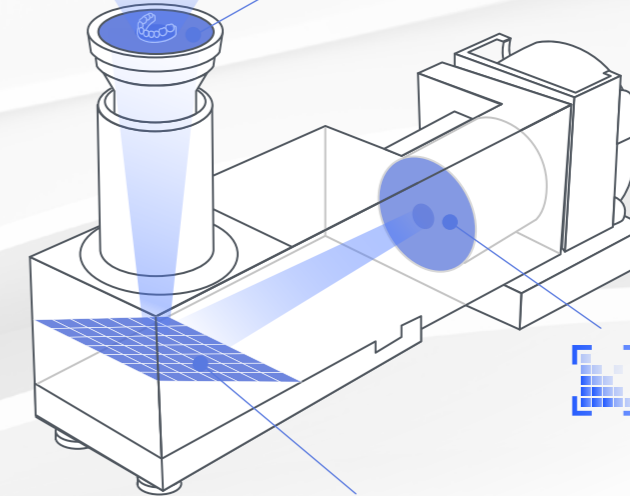

385 nm
Efficient **UV LED** Light Source

0.47" DMD Chip
Native **1080p** Resolution

02 Convenient Printing Adaptable to Various Environments

1



Protective Cover

99.9% UV blocking rate, reduces light interference and creates stable printing results.

2



Thermostatic Chamber

Maintains the optimum state for the resin with the proper room temperature and humidity.

3



Dust-proof Projector

IP5 dust resistance, protects production process from dust.

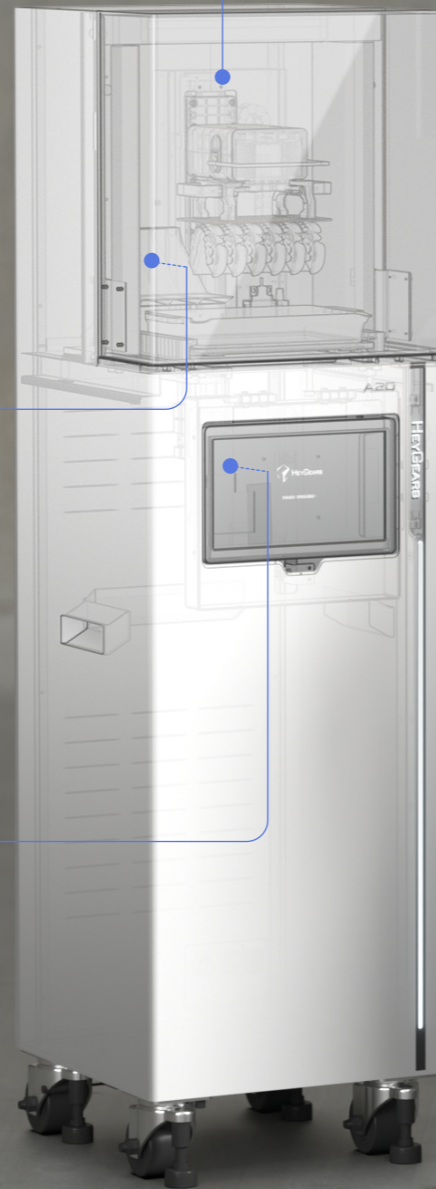

03 Lightweight and Compact Easy to Get Started

1



Visible Printing Process

The built-in UV-filtered light makes the printing process easy to monitor.

2



Switch within 10 Seconds

Quickly switch the platform and the material tray. No need to calibrate after switching.

3



Ergonomic Design

An inclined LCD panel allows you to see and operate it easily. The printing machine, build platform, material tray and LCD panel are at an optimum height for usage.

4



Status Light Strip

Set specific lighting effects according to the working status.

5



Hands-free Access

Easily open the printer cover using the lower foot sensor.



04 Over-the-air Updates Up-to-date Performance

- 1 OTA Remote Updates
- 2 Cloud Platform
- 3 AI Algorithm

Printing speed optimization based on data from force sensors, temperature and humidity sensors, and material status reports.

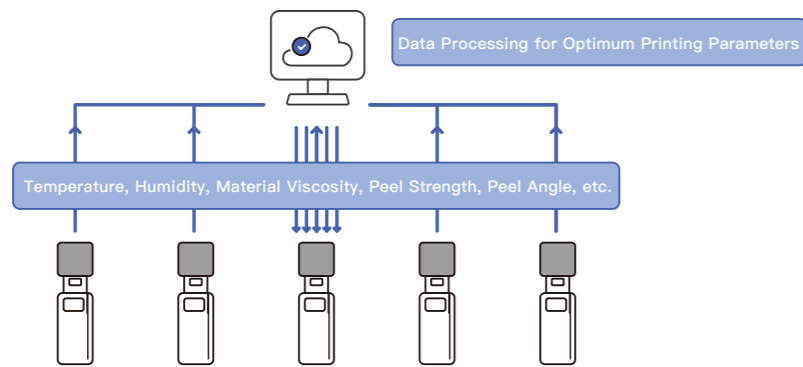

- Summarized printing record for the processing parameters of each printer
- Algorithm-enhanced analysis and training via the cloud
- Real-time feedback of processing parameters to the printers
- Greatly decrease the printing time and improve the stability with accurate parameters



05 Integrated Connection One-stop Complete Production

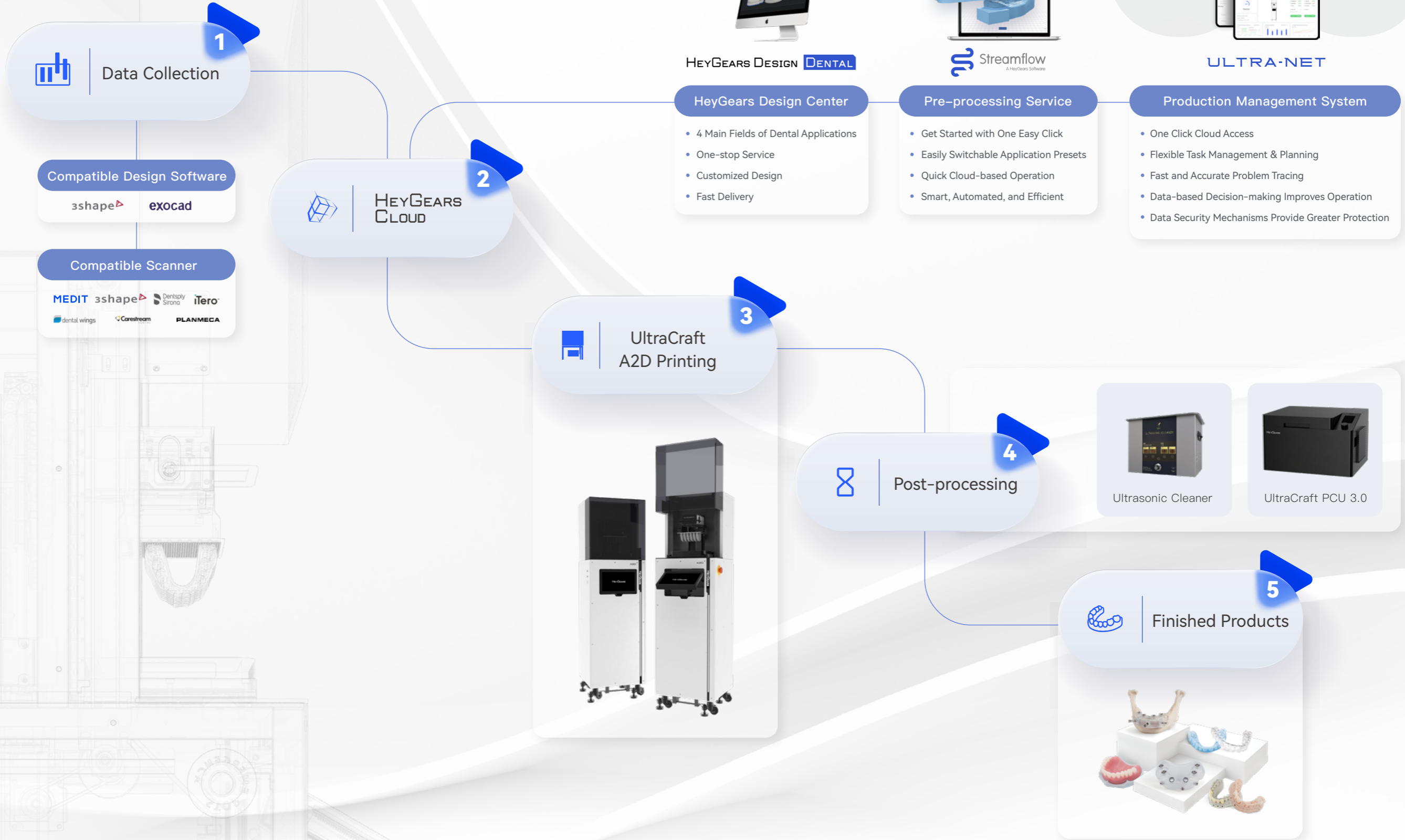

H
E
Y
G
E
A
R
S

A2D

06 Complete Dental Production Covering a Variety of Applications

50+

Dental Applications

4

Major Fields of Dentistry

1



Fixed Restoration

2



Removable Restoration

3



Implants

4



Orthodontics



Fixed Restoration

- Print 8 quadrant models within 55 mins (approx. 1 every 7 minutes)
- Print **111** pieces with 1 kg of high-precision Model HP UV resin



Surgical Guide (Tooth-supported)

- Print 8 guides within 30 minutes (approx. 1 every 5 minutes)
- Print **111** guides with 1 kg of Surgical Guide UV resin



Temp C&B

- Print 60 crowns and bridges within 35 minutes (approx. 1 every 35 seconds)
- Print **1250** pieces with 1 kg of Temp C&B UV resin



Complete Denture

- Print 6 denture bases within 170 minutes (approx. 1 every 28 minutes)
- Print **50** pieces with 1 kg of Denture Base UV resin



10+

High Performance Dental Materials

1



Compatible with Most
Dental Applications

2



Application-based
Material Matching

3



Continuous Research
and Development

07 Support for Digitalization

Support & Services



Quarterly Inspection

Regular equipment inspections, corresponding reports, and necessary online services for software upgrades and hardware optimization.



Equipment Maintenance

Early warning of potential faults, online maintenance, on-site support, and application fault diagnosis and repair. HeyGears offers free replacement for equipment that cannot be diagnosed and repaired due to faults or usage wear.



Further Support

If the maintenance exceeds 3 days, customers are able to send their printing tasks to HeyGears for printing.



Online & Offline
24/7 Support



Fast Response
Within 30 Minutes



On-site Service
Within 48 Hours

Worldwide Service Outlets

Headquarters: Guangzhou, China

Global Coverage: North America, Latin America, Europe, Middle East, and Asia Pacific

08 Specifications

Build Volume	144 x 81 x 110 mm 5.67 x 3.19 x 4.33 in
Resolution	1920 x 1080p
XY Native Pixel	75 μ m
Build Precision	\pm 37.5 μ m
Wavelength	385 nm
Light Source Lifetime	> 30,000 hours
Machine Dimension (W * D * H)	406 x 422 x 1426 mm 15.98 x 16.61 x 56.14 in
Weight	73.5 kg
Touchpad Size	11.6"
Voltage	110–220V AC, 50/60Hz, 400W